

20IND11 MetHyInfra

REPORT: Good Practice Guide on the dimensional characterisation of sonic nozzles (CFVNs) with different size, shape and surface roughness

DELIVERABLE D3

Lead partner: NEL

Authors:	Marc MacDonald, Chris Mills, Bodo Mickan, Marc de Huu, Edvardas Venslovas, Rémy Maury
Confidentiality:	Public
Submission date:	10.10.2022
Due date:	30.04.2022
Revision:	1.00

methyinfra.ptb.de

This project “Metrology infrastructure for high-pressure gas and liquified hydrogen flows” (MetHyInfra) has received funding from the EMPIR programme co-financed by the Participating States and from the European Union’s Horizon 2020 research and innovation programme.

Deliverable D3: REPORT: Good Practice Guide on the dimensional characterisation of sonic nozzles (CFVNs) with different size, shape and surface roughness	
Funding European Metrology Program for Innovation and Research	Grant agreement no: 20IND11
Project name Metrology infrastructure for high-pressure gas and liquified hydrogen flows	Project short name MetHyInfra
Author(s) Marc MacDonald TÜV SÜD National Engineering Laboratory marc.macdonald@tuvsud.com Chris Mills TÜV SÜD National Engineering Laboratory chris.mills@tuvsud.com Bodo Mickan Physikalisch-Technische Bundesanstalt, bodo.mickan@ptb.de Marc de Huu Federal Institute of Metrology, METAS Marc.deHuu@metas.ch Edvardas Venslovas Justervesenet <a href="mailto:Edvardas Venslovas <eve@justervesenet.no>">Edvardas Venslovas <eve@justervesenet.no> Rémy Maury CESAME r.maur@cesame-exadebit.fr	Pages 12 pages
<p>Summary</p> <p>This report was written as part of activity A2.3.4 from the EMPIR Metrology infrastructure for high-pressure gas and liquified hydrogen flows (MetHyInfra) project. The three-year European project commenced on 1st June 2021 and focused on providing metrological infrastructure and traceability for high pressure hydrogen flow meter calibration (1000 bar / 3.6 kg/min), fuel cells applications (4 kg/h, 30 bar) and liquid hydrogen. For more details about this project please visit methyinfra.ptb.de.</p> <p>The report details the parameters of interest for dimensional characterisation of sonic nozzles, and presents a procedure that can be followed for performing the measurements and data analysis.</p>	
Confidentiality	Public

Contents

1	Introduction.....	3
2	Key Dimensional Parameters	3
2.1	Determination of dry Discharge Coefficient.....	3
2.2	Throat Diameter	4
2.3	Inlet Curvature.....	4
2.4	Roughness	5
2.5	Flow Calibration.....	6
3	Measurement Technique	7
3.1	Coordinate Measuring Machine (CMM)	7
4	Measurement procedure	7
5	Analysis of Dimensional Measurements	9
6	Conclusion	11
7	References.....	12

1 Introduction

The MetHyInfra project seeks to establish sonic nozzles as flow standards for high pressure hydrogen. Sonic nozzles are already widely used for gas flow measurement, due their excellent repeatability and reproducibility, long-term stability and well understood flow behaviour. The ISO 9300:2022 standard [1] provides detailed guidance on the construction, installation and operation of sonic nozzles, and reliable calculation methods for important fluid properties and overall mass flow rate calculation. Considering hydrogen metrology, one of the key advantages to using sonic nozzles is that they can likely provide accurate hydrogen flow measurements without the need to first calibrate the nozzle with a hydrogen primary flow standard. Indeed, it is already possible to accurately measure the flow rate of gases using sonic nozzles that have not been subject to a flow calibration, and the MetHyInfra project aims to show that hydrogen is one of the many gases for which this is possible.

Without a flow calibration, it is necessary to accurately characterise the shape and inner geometry of the sonic nozzle. The most established method is to construct a nozzle to the tolerances specified in ISO 9300:2022 and apply the calculation methods provided by the standard. However, ensuring that the nozzle geometry is conformant to the standard is not always straightforward, particularly for smaller nozzles with throat diameters of the order of 1 mm or below. Nozzles with throat diameters of 1 mm and 2 mm have been constructed, measured, and calibrated with both air and hydrogen in the course of the MetHyInfra project. This document provides good practice on dimensional characterisation of sonic nozzles, informed by the findings of the project and the accumulated knowledge of its consortium.

2 Key Dimensional Parameters

2.1 Determination of dry Discharge Coefficient

In this document references are made to the “dry” discharge coefficient, this is the discharge coefficient determined by dimensional measurements of the nozzle and application of fluid dynamics modelling, as opposed to the discharge coefficient determined by a flow calibration (or the “wet” discharge coefficient.) Note that the designation of “dry” or “wet” does not imply an accuracy level, many researchers have successfully determined dry discharge coefficients which are equivalent with wet discharge coefficients derived from highly accurate flow calibrations.

There are two general approaches which can be taken to determine the dry discharge coefficient as a function of the nozzle geometry and flow conditions, these are:

- ISO 9300:2022 method: discharge coefficient is calculated as a function of Reynolds number only, but the nozzle must conform to the geometric parameters and associated tolerances specified by the standard. The calculation method is only applicable within the specified Reynolds number ranges.
- Application of other models for sonic nozzle flow. Various models are found in the academic literature, based on application of the Navier-Stokes equations. These modelling approaches are not discussed in detail in this report.

Regardless of how the dry discharge coefficient is determined, accurate measurements of the same geometric parameters are needed.

diameter, $r_c = d_{nt}$. In the contraction, the shape shall not deviate from the torus by more than $\pm 0.001 d_{nt}$. The throat section is a cylinder of length d_{nt} and diameter d_{nt} .

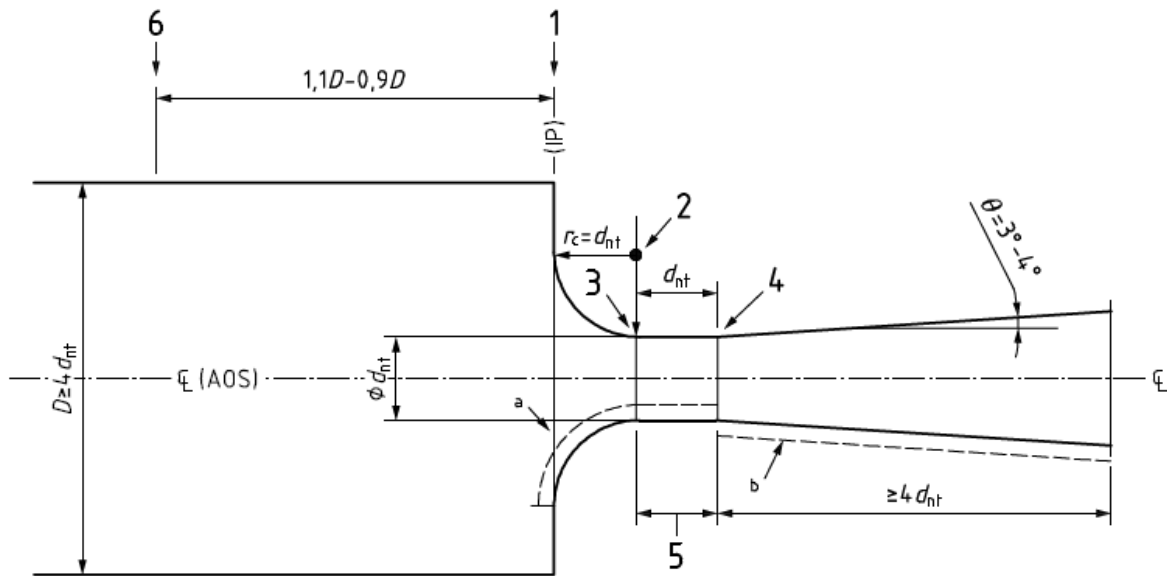

Figure 2: ISO 9300:2022 cylindrical-throat geometry

The curvature radius is a key parameter in the dimensional characterisation of sonic nozzles and determination of the dry discharge coefficient. There are many studies which corroborate that for the toroidal-throat nozzle, a curvature radius of $r_c = 2d$ and tolerance of $\pm 10\%$ provide accurate discharge coefficient determination. For example, a study by NIST [2] found that variations of 10% or less in the curvature radius introduced errors of less than 0.02% on dry discharge coefficient for the Reynolds number range considered. Another study by PTB [3] found that $r_c = 2d$ provided an optimum condition where the curve of discharge coefficient vs. Reynolds number was less sensitive to deviations in r_c compared to larger and smaller values of r_c .

While a reasonably high uncertainty in the curvature ratio is accepted, the tolerance for conformity to the toroidal shape is quite strict, corresponding to $\pm 5 \mu\text{m}$ for a nozzle based on a 5 mm throat diameter, or $\pm 1 \mu\text{m}$ for a 1 mm throat.

2.4 Roughness

ISO 9300:2022 requires that the section of the nozzle shall be smoothly finished, the maximum allowable arithmetic average roughness, R_a is

For $d_{nt} > 13 \text{ mm}$: $R_a = 15 \times 10^{-6} d_{nt}$ as a maximum requirement, and

For $d_{nt} \leq 13 \text{ mm}$: $R_a = 200 \text{ nm}$ as a maximum requirement

i.e. for a nozzle with throat diameter of 20 mm, the required arithmetic average roughness R_a is 0.3 μm or less. The roughness required for nozzles throat diameters up to 13 mm is fixed at 0.2 μm .

For context, the typical roughness levels achieved by different manufacturing methods are shown in Table 1.

Table 1: Typical roughness values for critical flow nozzles manufactured by different methods

Manufacturing method	Arithmetic average roughness, Ra
Spark eroded	> 1 μm
Standard lathe, unpolished	< 1 μm
Standard lathe, polished	Approx. 0.4 μm
Standard lathe, well-polished	Approx. 0.1 μm
Super-accurate lathe, unpolished	Approx. 0.03 μm

Therefore, there are two common approaches to achieving the required roughness level. The first is to use a standard lathe and then polish the nozzle inlet surface until the required roughness level is achieved. This is defined in ISO 9300:2022 as a “normal precision nozzle (NPN)”. Often quantitative roughness data is not available, and the user will simply polish until a mirror finish is achieved. However, polishing procedures often change the local curvature of the torus. Alternatively, the nozzle can be machined using a highly accurate lathe that is capable of achieving a mirror finish without polishing. This is defined in ISO 9300:2022 as a “high precision nozzle (HPN)”.

Accurate measurement of surface roughness can be very challenging, particularly for small nozzles due to the restricted access near the throat. Several studies have been carried out to investigate the sensitivity of the nozzle flow behaviour to surface roughness. Wendt & Lavante [4] investigated roughness effects on sonic nozzles of with diameters of 0.15 mm to 10 mm. Their results showed that the effect of roughness was negligible up to $Ra/d = 2 \times 10^{-4}$ – up to 10 times larger than the limit stipulated in ISO 9300:2022. They found that there were no systematic or significant differences in the nozzle flow behaviour when roughness levels were varied between 0.1 μm and 1 μm , and suggested that industrial users of normally machined nozzles could expect reliable flow behaviour even when nozzles were unpolished and failing to meet the roughness requirements of the standard. Gibson et. al [5] studied nozzles with 10 mm throat diameters and found that the effect of roughness was negligible for $Ra/d < 4.5 \times 10^{-5}$ (2.25 times the limit stipulated in ISO 9300:2022).

Investigations on cylindrical nozzles performed by Lambert [6] indicated clearly that roughness is only an important issue for operation at high Reynolds numbers when the boundary layer in the nozzles becomes turbulent. Nozzles with sizes from 5 mm to 10 mm throat had been studied with roughness levels from $Ra/d = 5 \times 10^{-5}$ to 2×10^{-4} . Similar to the outcome of studies mentioned above, there were no effect on the c_D by roughness level below a certain limit of Reynolds number, but a severe effect above that limit with clear dependency on roughness level.

2.5 Flow Calibration

Although the subject of this report is dimensional calibration of nozzles, it is known that larger tolerances in the nozzle geometry can be accepted if the wet discharge coefficient is determined by flow calibration. This is due to cancellation of several uncertainty contributions of the nozzle geometry. For example, it is not necessary to measure the curvature radius of the nozzle if the mass flow rate behaviour is to be determined by flow calibration. Similarly, it is accepted practice that a nominal throat diameter can be used, even with a very large measurement uncertainty. In this case, any error in the diameter will shift the flow calibration curve, but this shift is compensated for when the calibration curve is later applied by the end user to calculate mass flow rate. Provided that the same nominal diameter is used for both the flow calibration and the end user application of the nozzle,

uncertainty in the throat diameter is fully correlated and has a negligible contribution to the overall uncertainty in mass flow rate.

This approach is not entirely risk-free, because without accurate dimensional measurements of the nozzle it is difficult to confirm that there are no significant geometrical defects. Deviations from the ISO 9300:2022 nozzle shape can result in an unusual curve of discharge coefficient vs. Reynolds number. In most operating conditions, a user could accept an unusual nozzle geometry because the flow behaviour is still well characterised by the flow calibration. However, under specific conditions, unusual flow behaviour may occur, such as a sharp change in discharge coefficient or premature unchoking. These considerations are particularly relevant when small nozzles are used, because fabrication to the required tolerances is more difficult to achieve and because irregularities in the inner geometry have a greater relative influence on the flow behaviour. Users of sonic nozzles are advised to seek expert advice in cases where nozzle geometry or operating conditions depart from those advised in the available documentary standards.

3 Measurement Technique

3.1 Coordinate Measuring Machine (CMM)

It is recommended to use coordinate measuring machines for the dimensional calibrations. A coordinate measuring machine (CMM) is a device which uses probes to measure the distances between points on an object in a three-dimensional coordinate system. In addition to moving the probe along the X, Y, and Z axes, many machines also allow the probe angle to be controlled to allow measurement of surfaces that would otherwise be unreachable.

The contact probe method is still used in many CMMs although some use a variant which drags along a surface and take measurements at specified intervals, these are known as scanning probes and are often faster and more accurate than the conventional touch-probe method. Non-contact methods are also used including optical and laser types. Modern CMMs are available both with manual remote control and automated CNC control.

CMMs are widely used for quality control in industries such as aerospace, automobile and heavy manufacturing and are increasingly common in small machine shops. They are also employed by national metrology institutes for dimensional measurements including in high-aspect ratio internal geometries such as sonic nozzles. This is still challenging for smaller nozzle sizes with throat diameters of around 1 mm or below, as conventional CMM probes end at 300 μm diameter of the probing spheres. Micro-CMMs now offer smaller probing spheres with diameters down to 120 μm , or in the case of the fibre probes down to 20 μm .

Overall, CMMs are well suited to dimensional measurements of sonic nozzles and can provide accurate measurements for all parameters except roughness. The METAS CMM was used for measurements of throat diameter, curvature radius and concentricity of the sonic nozzles built for the MetHyInfra project.

4 Measurement procedure

As described in Section 2, there are two essential parameters that must be determined from the dimensional measurements: the shape of the nozzle in the axial direction, z and the throat diameter, d_{nt} . Figure 3 illustrates a scheme that can be followed to collect the necessary measurements from fixed points on the nozzle internal surface, following 8 surface lines in the axial (flow) direction which

are spaced 45° apart around the circumference. A greater number of surface lines can be measurement in cases where there are doubts about the roundness of a particular nozzle.

From these 8 surface lines, the location of the throat has to be determined (see Section 5). A circle with a greater number of points (e.g. 360 points spaced 1° apart) at the throat shall be measured to obtain a precise measurement of the throat area and greater detail on the roundness of the nozzle.

It is not necessary to take measurement points too far upstream of the throat, because the impact of boundary layer development at low Mach numbers has no significant impact on discharge coefficient, C_D . For the final measurement in the axial direction, it should be confirmed during the measurement that the throat is past, by ensuring there is a minimal increase in heigh Δh visible in successive measurements in the z-direction. Figure 4 and Table 2 show values which have been tested in practice.

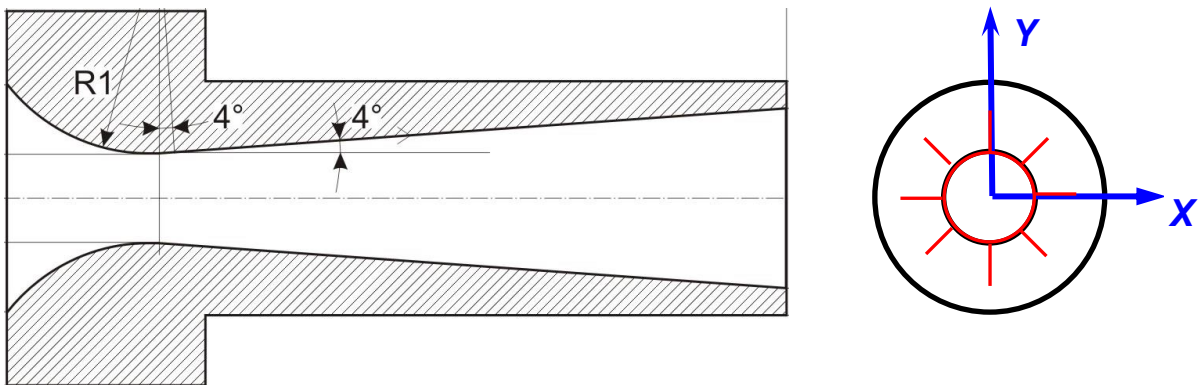

Figure 3: Scheme of surface lines in z-direction (flow direction) with 45° circumferential distribution.

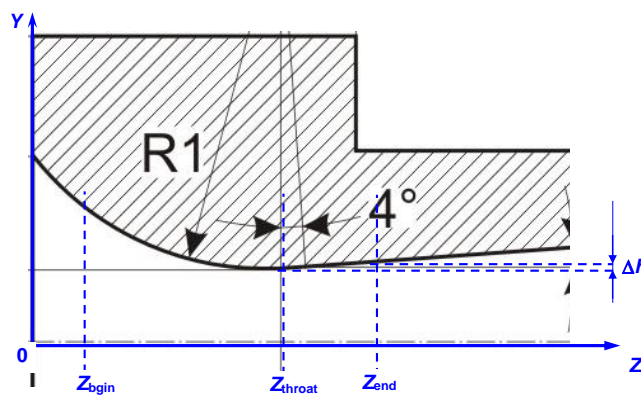

Figure 4: specific z-positions for surface line measurement

Table 1: Normalised values for specific z-positions for surface line measurement, see also Fig. 2

Table 2: Normalised values for specific z-positions for surface line measurement, see also Fig. 2

z_{begin}/d_{throat}	z_{throat}/d_{throat}	z_{end}/d_{throat}	$\Delta h/d_{throat}$ minimum
0,304	1,732	2,012	0,0195

To fix the number of points for a measurement of a surface line along the z-direction, we advise to orientate on the dimension of displacement thickness. The displacement thickness has approximately a size of $\delta_1/d_{\text{throat}} \approx (1-c_D)/4$, hence with a c_D in order of 0.995 one gets $\delta_1/d_{\text{throat}} \approx 0.00125$. A point distance of roughly 5 to 10 times of this size is recommendable, i.e. $\Delta z/d_{\text{throat}} \leq 0.01$ is sufficient. Using the values of z_{begin} and z_{end} of Table 2 we get approximately 200 points per surface line.

5 Analysis of Dimensional Measurements

The throat area with respect to the throat diameter must be determined from the high-resolution circle at the throat position by means of least squares fit (LSF) of a circle to the x-y coordinates. There are well-established algorithms that can be used for this.

The second parameter of interest is the local curvature of the nozzle in the flow direction, determination of which requires multiple steps.

First, for each z-position, there are eight x-y coordinates of the eight surface lines, which are also approximated by a circle to obtain a local radius, $r(z)$ of the nozzle at that z-position as well as the centre point $[x_m(z), y_m(z)]$ of this circle. The development of $[x_m(z), y_m(z)]$ along the z-axis provides an indication of the centricity of the nozzle.

Also, there are residuals between the fitted circle and the measured points. All together the residuals for all z-positions when plotted versus the z-position give a first estimate of the nozzle surface quality. It should be noted that a precise roughness measurement is not provided using this approach, since the probing sphere of CMMs are much too large, but the waviness can at least be evaluated from the set of residuals.

To evaluate the radius of curvature, R_C with respect to the local curvature Ω of the nozzle we need the first and second derivative of the local diameters with respect to the z-coordinate:

$$\frac{1}{R_C} = \Omega = \frac{\dot{r}}{(1 + \dot{r}^2)^{1.5}}$$

The direct numerical derivatives of the values $r(z)$ are much usually too noisy to provide useful information, and filtering is essential. Application of the Savitzky-Golay filter is recommended to maintain the local characteristics of the shape. Figure 5 to Figure 7 show the effect of filtering on the derivatives of for a real measured nozzle. The surface lines of the nozzles have been measured with a point distance of $\Delta z/d_{\text{throat}} = 0.0077$. Figure 5 is using the direct numerical derivatives and the nozzle would not pass the ISO 9300:2022 requirements for shape. Figure 6 shows the same shape after filtering of $r(z)$ with a second-order Savitzky-Golay-Filter using 9 points, i.e. a span of $\Delta z_{\text{filter}}/d_{\text{throat}} = 0.065$. Finally, Figure 7 shows the situation applying a second-order Savitzky-Golay-Filter using 17 points, i.e. a span of $\Delta z_{\text{filter}}/d_{\text{throat}} = 0.13$. The example illustrates the essential impact of filtering to the outcome of evaluation. Up to now, there is no strong criteria for determination of the filter characteristics available. It is recommended to check the differences (residuals) of the original $r(z)$ to the filtered shape $r_{\text{filtered}}(z)$. At least, these differences should be smaller than the expected displacement thickness but better also smaller than the momentum thickness.

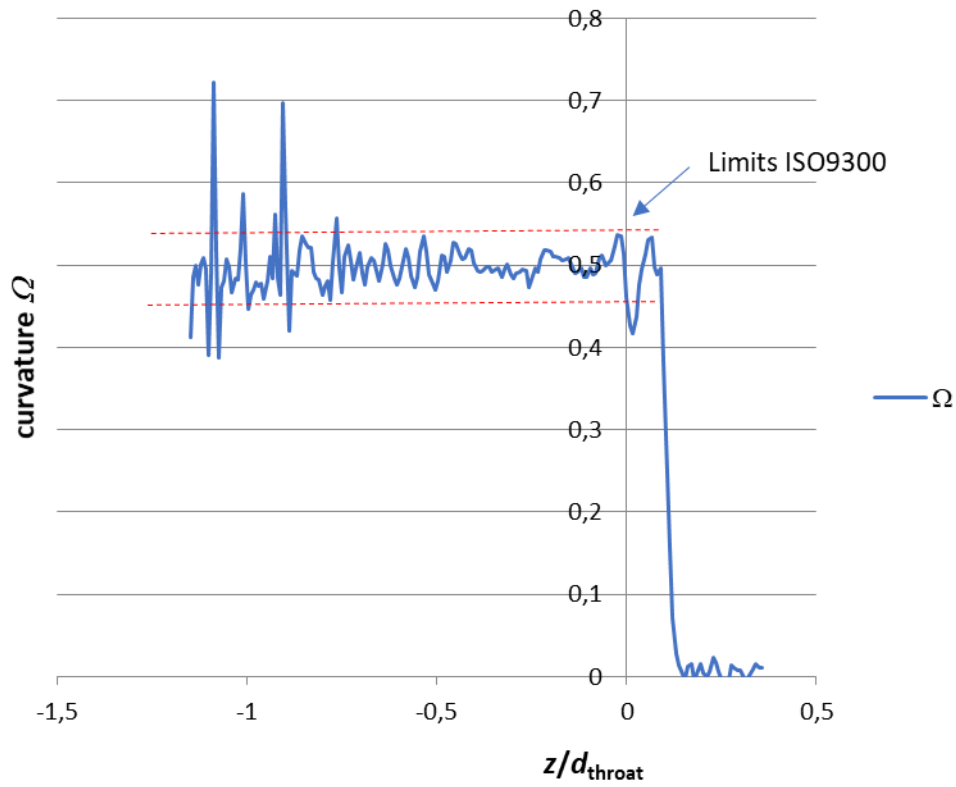

Figure 5: Curvature using direct numerical derivatives of $r(z)$

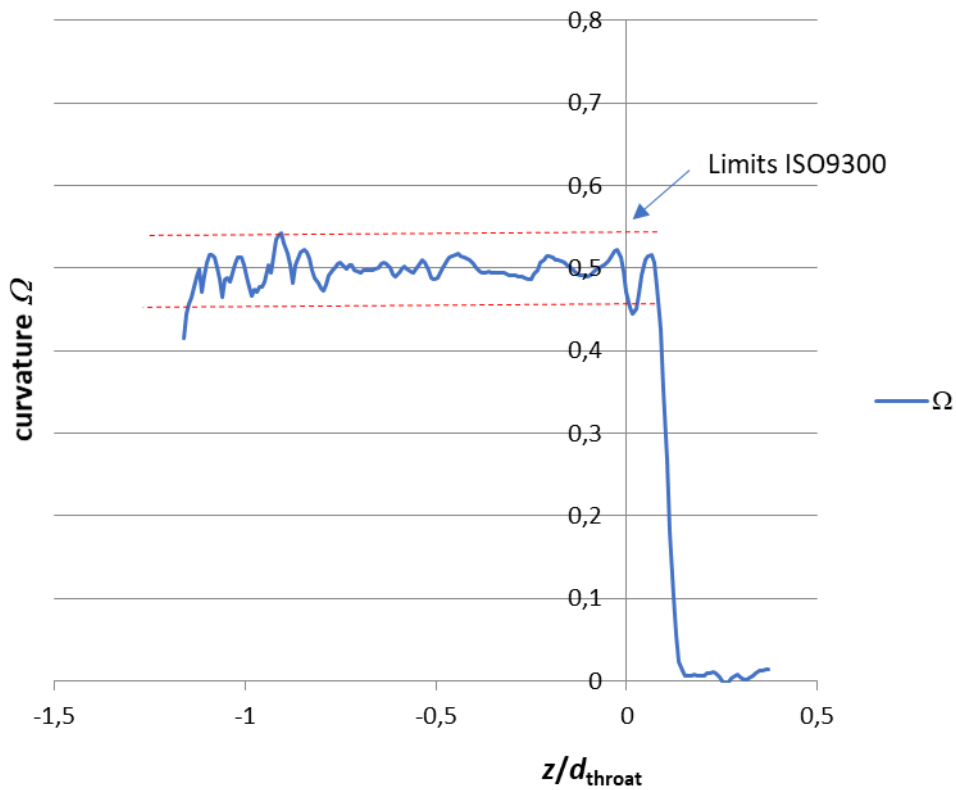

Figure 6: Curvature using 9-Point Second-Order Savitzky-Golay-Filter

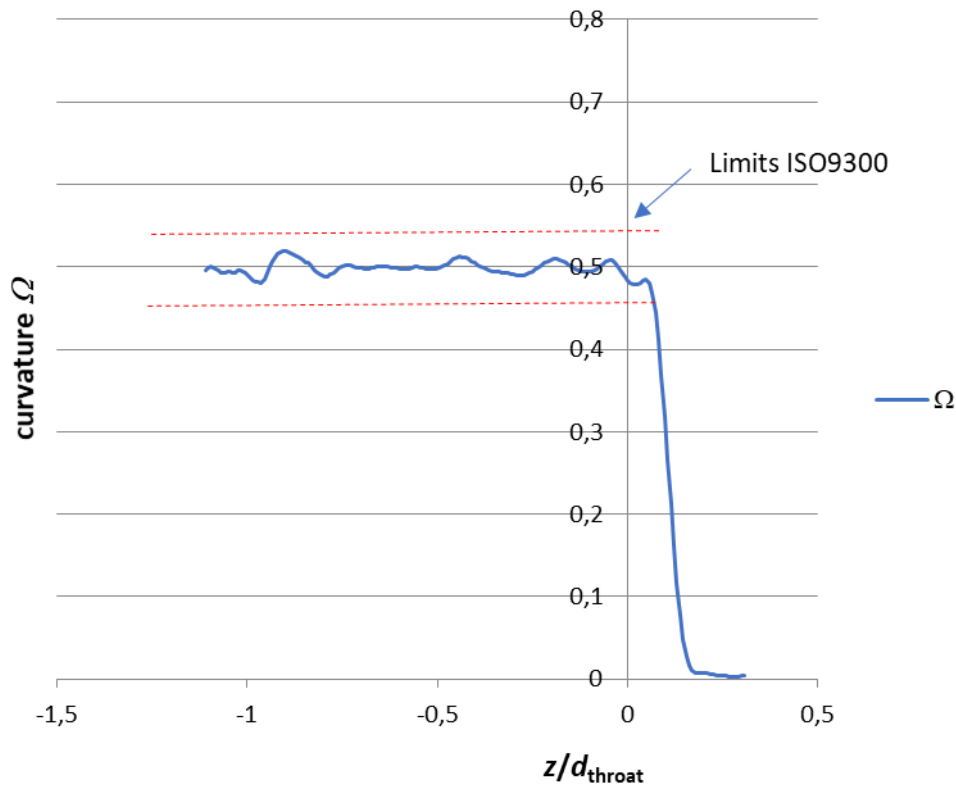

Figure 7: Curvature using 17-Point Second-Order Savitzky-Golay-Filter

As previously mentioned, the CMM measurements do not allow the roughness to be specified in the sense of a scientific roughness definition. Nevertheless, the level and distribution of residuals of the different approximations (from determination of local radius $r(z)$ as well as from filtering the $r(z)$) indicate a surface quality. Using the definitions and algorithm for roughness values on these sets of data will lead to quantified statements (which should not be called roughness to avoid conflicts in understanding) that can be used in a similar way for further investigations. Other than the definition of R_a , it is highly recommended to use the definition of R_z because the R_z value seems to be closer related to the impact of roughness to the boundary layer development than R_a , see Adams et al. [7]

6 Conclusion

Sonic nozzles have the potential to provide accurate flow measurement of hydrogen without the need for flow calibration. In order to determine the dry discharge coefficient, it is necessary to perform a dimensional characterisation and confirm that the nozzle shape conforms to the ISO 9300:2022 tolerances. The most important parameters for the dimensional characterisation are measurements of throat diameter and local curvature in the throat direction. It is challenging to perform these measurements, particularly for small nozzles (throat diameters of 1 mm or less). This guide outlines a procedure for performing the measurements and data analysis, which has been successfully applied during the project to sonic nozzles based on 1 mm and 2 mm throat diameters.

7 References

- [1] International Organisation for Standardization, *ISO 9300:2022 Measurement of gas flow by means of critical flow nozzles*, 2022.
- [2] A. Johnson and J. Wright, "Comparison Between Theoretical CFV Flow Models and NIST's Primary Flow Data in the Laminar, Turbulent and Transition Flow Regimes," *Journal of Fluids Engineering*, Vol. 130, 2008.
- [3] B. Mickan, J. van der Grinten and T. Kappes, "Primary and secondary flow standards for a wide variety of gas compositions - a solid base for reliable traceability facing the energy transition," in *North Sea Flow Measurement Workshop*, 2020.
- [4] G. Wendt and E. von Lavante, "Influence of Surface Roughness on the Flowrate Behaviour of Small Critical Venturi Nozzles," in *Flomeko*, Salvador, Bahia, Brazil, 2000.
- [5] J. Gibson, D. Stewart and N. Barton, "Considerations for ISO 9300 - The Effects of Roughness and Form on the Discharge Coefficient of Toroidal Throat Sonic Nozzles," in *Proceedings of ASME FEDSM'03*, Honolulu, Hawaii, USA, 2003.
- [6] M. Lambert, R. Maury, J.-C. Valière, E. Foucault and G. Lehnasch, "Experimental and numerical investigations on the shape and roughness of cylindrical critical flow venturi nozzles (CFVN)," in *19th International Congress of Metrology*, Paris, 2019.
- [7] T. Adams, C. Grant and H. Watson, "A Simple Algorithm to Relate Measured Surface Roughness to Equivalent Sand-grain Roughness," *International Journal of Mechanical Engineering and Mechatronics (IJMEM)*, vol. 1, no. 2, pp. 66-71, 2012.